



ENHANCEMENT OF POWER QUALITY IMPROVEMENT GRID-CONNECTED DUAL VOLTAGE SOURCE INVERTER

1. MANTHENA RAGHUVARAN, 2. G RATNA KUMARI 3 RAMAVATH SHANKAR NAIK

1.Pg Scholar, Department of EEE, SLC's Institute of Engineering and Technology,Hyderabad.

2.Assistant Professor Department Of EEE, SLC's Institute of Engineering and Technology, Hyderabad.

.3.Associate Professor& HOD, Department Of EEE, SLC's Institute of Engineering and Technology, Hyderabad

ABSTRACT:

The main aim of project is to improve the power quality by using fuzzy based grid connected dual voltage source inverter. The new scheme is comprised of two inverters, which enables the microgrid to exchange power generated by the distributed energy resources (DERs) and also to compensate the local unbalanced and nonlinear load. The control algorithms are developed based on instantaneous symmetrical component theory (ISCT) to operate DVSI in grid sharing and grid injecting modes. The proposed scheme has increased reliability, lower bandwidth requirement of the main inverter, lower cost due to reduction in filter size, and better utilization of microgrid power while using reduced dc-link voltage rating for the main inverter. These features make the DVSI scheme a promising option for microgrid supplying sensitive loads. the proposed topology validated through simulation results.

Index Terms: Power quality, Distributed energy source,Fuzzycontroller,Grid connected inverter, instantaneous symmetrical component theory (ISCT).

1.INTRODUCTION

The proliferation of power electronics devices and electrical loads with unbalanced nonlinear currents has degraded the power quality in the power distribution network. Moreover, if there is a considerable amount of feeder impedance in the distribution systems, the propagation of these harmonic currents distorts the voltage at the point of common coupling (PCC). At the same instant, industry automation has reached to a very high level of sophistication, where plants like automobile manufacturing units, chemical factories, and semiconductor industries require clean power.

For these applications, it is essential to compensate nonlinear and unbalanced load currents. Load compensation and power injection using grid interactive inverters in microgrid have been presented in the literature.

A single inverter system with power quality enhancement is discussed in. The main focus of this work is to realize dual functionalities in an inverter that would provide the active power injection from a solar PV system and also works as an active power filter, compensating unbalances and the reactive power required by other loads connected to the system. In , a voltage regulation and power flow control scheme for a wind energy system (WES) is proposed. A distribution static compensator (DSTATCOM) is utilized for voltage regulation and also for active power injection. The control scheme maintains the power balance at the grid terminal during the wind variations using sliding mode control. A multifunctional power electronic converter for the DG power system is described. This scheme has the capability to inject power generated by WES and also to perform as a harmonic compensator. Most of the reported literature in this area discuss the topologies and control algorithms to provide load compensation capability in the same inverter in addition to their active power injection. When a grid-connected inverter is used for active power injection as well as for load compensation, the inverter capacity that can be utilized for achieving the second objective is decided by the available instantaneous microgrid real power. Considering the case of a grid-connected PV inverter, the available capacity of the inverter to supply the reactive power becomes less during the maximum solar insolation periods.

At the same instant, the reactive power to regulate the PCC voltage is very much needed during this period. It indicates that providing multi functionalities in a single inverter degrades either the real power injection or the load compensation capabilities. This paper demonstrates a dual voltage source inverter (DVSI) scheme, in which the power generated by the microgrid is injected as real power by the main voltage source inverter (MVS) and the reactive, harmonic, and unbalanced load compensation is performed by auxiliary voltage source inverter (AVSI). This has an advantage that the rated capacity of MVS can always be used to inject



real power to the grid, if sufficient renewable power is available at the dc link.

In the DVSI scheme, as total load power is supplied by two inverters, power losses across the semiconductor switches of each inverter are reduced. This increases its reliability as compared to a single inverter with multifunctional capabilities. Also, smaller size modular inverters can operate at high switching frequencies with a reduced size of interfacing inductor, the filter cost gets reduced. Moreover, as the main inverter is supplying real power, the inverter has to track the fundamental positive sequence of current. This reduces the bandwidth requirement of the main inverter. The inverters in the proposed scheme use two separate dc links. Since the auxiliary inverter is supplying zero sequence of load current, a three-phase three-leg inverter topology with a single dc storage capacitor can be used for the main inverter. This in turn reduces the dc-link voltage requirement of the main inverter. Thus, the use of two separate inverters in the proposed DVSI scheme provides increased reliability, better utilization of microgrid power, reduced dc grid voltage rating, less bandwidth requirement of the main inverter, and reduced filter size. Control algorithms are developed by instantaneous symmetrical component theory (ISCT) to operate DVSI in grid-connected mode, while considering nonstiff grid voltage.

II. DUAL VOLTAGE SOURCE INVERTER

A. System Topology

The proposed DVSI topology is shown in Fig. It consists of a neutral point clamped (NPC) inverter to realize AVSI and a three-leg inverter for MVSI [18]. These are connected to grid at the PCC and supplying a nonlinear and unbalanced load. The function of the AVSI is to compensate the reactive, harmonics, and unbalance components in load currents. Here, load currents in three phases are represented by i_{la} , i_{lb} , and i_{lc} , respectively. Also, $i_g(abc)$, $i_{ugm}(abc)$, and $i_{ugx}(abc)$ show grid currents, MVSI currents, and AVSI currents in three phases, respectively. The dc link of the AVSI utilizes a split capacitor topology, with two capacitors C_1 and C_2 . The MVSI delivers the available power at distributed energy resource (DER) to grid. The DER can be a dc source or an ac source with rectifier coupled to dc link. Usually, renewable energy sources like fuel cell and PV generate power at variable low dc voltage, while the variable speed wind turbines generate power at variable ac voltage. Therefore, the power generated from these sources use a power conditioning stage before it is connected to the input of MVSI. In this study, DER is being represented as a dc source. An inductor filter is used to eliminate the high-frequency switching components generated due to the switching of power electronic switches in the inverters. The system considered in this study is assumed to have some amount of feeder resistance R_g and inductance L_g . Due to the presence of this feeder impedance, PCC voltage is affected with harmonics. Section III describes the extraction

of fundamental positive sequence of PCC voltages and control strategy for the reference current generation of two inverters in DVSI scheme.

Design of DVSI Parameters

1) AVSI:

The important parameters of AVSI like dc-link voltage (V_{dc}), dc storage capacitors (C_1 and C_2), interfacing inductance (L_{fk}), and hysteresis band ($\pm hx$) are selected based on the design method of split capacitor STATCOM topology [16]. The dc-link voltage across each capacitor is taken as 1.6 times the peak of phase voltage. The total dc-link voltage reference (V_{dcref}) is found to be 1040 V. Values of dc capacitors of AVSI are chosen based on the change in dc-link voltage during transients. Let total load rating is S kVA. In the worst case, the load power may vary from minimum to maximum, i.e., from 0 to S kVA. AVSI needs to exchange real power during transient to maintain the load power demand. This transfer of real power during the transient will result in deviation of capacitor voltage from its reference value.

Assume that the voltage controller takes n cycles, i.e., nT seconds to act, where T is the system time period. Hence, maximum energy exchange by AVSI during transient will be nST . This energy will be equal to change in the capacitor stored energy. Therefore

$$\frac{1}{2} C_1 (V_{dcr}^2 - V_{dc1}^2) = nST$$

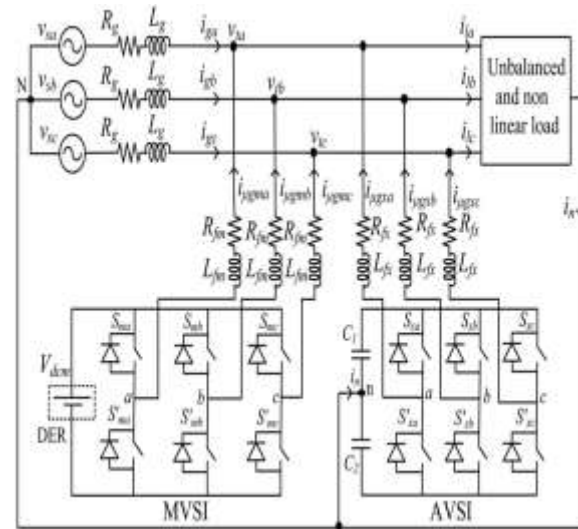

Fig.4. Topology of DVSI scheme

where V_{dcr} and V_{dc1} are the reference dc voltage and maximum permissible dc voltage across C_1 during transient, respectively. Here, $S = 5$ kVA, $V_{dcr} = 520$ V, $V_{dc1} = 0.8 * V_{dcr}$ or $1.2 * V_{dcr}$, $n = 1$, and T



= 0.02 s. Substituting these values in (1), the dclink capacitance (C1) is calculated to be 2000 μF. Same value of capacitance is selected for C2. The interfacing inductance is given by

$$L_{fx} = \frac{1.6 V_m}{4 h_x f_{max}}$$

Assuming a maximum switching frequency (fmax) of 10 kHz and hysteresis band (hx) as 5%of load current (0.5 A), the value of L_{fx} is calculated to be 26 mH.

2) MVSI:

The MVSI uses a three-leg inverter topology. Its d-link voltage is obtained as 1.15 * V_{ml}, where V_{ml} is the peak value of line voltage. This is calculated to be 648 V. Also, MVSI supplies a balanced sinusoidal current at unity power factor. So, zero sequence switching harmonics will be absent in the output current of MVSI. This reduces the filter requirement for MVSI as compared to AVSI. In this analysis, a filter inductance (L_{fm}) of 5 mH is used.

III. CONTROL STRATEGY FOR DVSI SCHEME

A. Fundamental Voltage Extraction

The control algorithm for reference current generation using ISCT requires balanced sinusoidal PCC voltages. Because of the presence of feeder impedance, PCC voltages are distorted. Therefore, the fundamental positive sequence components of the PCC voltages are extracted for the reference current generation. To convert the distorted PCC voltages to balanced sinusoidal voltages, dq0 transformation is used. The PCC voltages in natural reference frame (v_{ta}, v_{tb}, and v_{tc}) are first transformed into dq0 reference frame as given by

$$\begin{bmatrix} v_{td} \\ v_{tq} \\ v_{t0} \end{bmatrix} = C \begin{bmatrix} v_{ta} \\ v_{tb} \\ v_{tc} \end{bmatrix}$$

where

$$C = \sqrt{\frac{2}{3}} \begin{bmatrix} \sin \theta & \sin(\theta - \frac{2\pi}{3}) & \sin(\theta + \frac{2\pi}{3}) \\ \cos \theta & \cos(\theta - \frac{2\pi}{3}) & \cos(\theta + \frac{2\pi}{3}) \\ \frac{1}{\sqrt{2}} & \frac{1}{\sqrt{2}} & \frac{1}{\sqrt{2}} \end{bmatrix}$$

In order to get θ, a modified synchronous reference frame (SRF) phase locked loop (PLL) [23] is used. The schematic diagram of this PLL is shown in Fig. It mainly consists of a proportional integral (PI) controller and an integrator. In

this PLL, the SRF terminal voltage in q-axis (vtq) is compared with 0 V and the error voltage thus obtained is given to the PI controller. The frequency deviation Δω is then added to the reference frequency ω0 and finally given to the integrator to get θ. It can be proved that, when, θ = ω0 t and by using the Park’s transformation matrix (C), q-axis voltage in dq0 frame becomes zero and hence the PLL will be locked to the reference frequency (ω0).

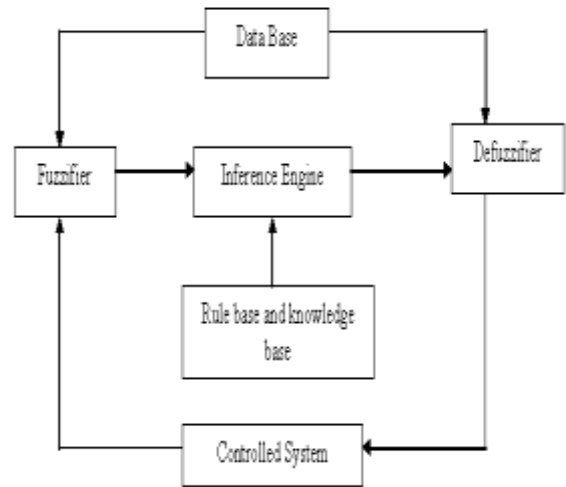

Fig.5 Schematic diagram of FL.

B. Instantaneous Symmetrical Component Theory

ISCT was developed primarily for unbalanced and nonlinear load compensations by active power filters. The system topology shown in Fig is used for realizing the reference current for the compensator. The ISCT for load compensation is derived based on the following threeconditions.

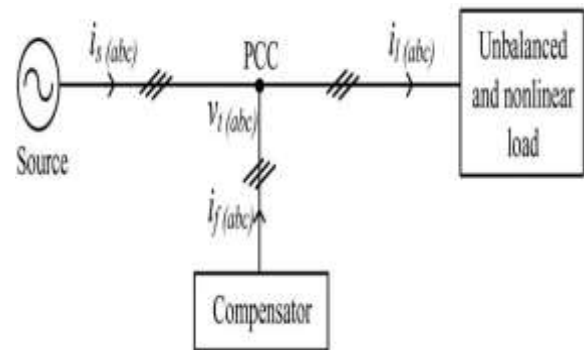

Fig.6. Schematic of an unbalanced and nonlinear load compensation scheme.

- 1) The source neutral current must be zero. Therefore



$$i_{sa} + i_{sb} + i_{sc} = 0. \tag{6}$$

- 2) The phase angle between the fundamental positive sequence voltage (v_{ta1}) and source current (i_{sa}) is ϕ

$$\angle v_{ta1} = \angle i_{sa} + \phi. \tag{7}$$

- 3) The average real power of the load (P_l) should be supplied by the source

$$v_{ta1}^+ i_{sa} + v_{tb1}^+ i_{sb} + v_{tc1}^+ i_{sc} = P_l. \tag{8}$$

Solving the above three equations, the reference source currents can be obtained as

$$\begin{aligned} i_{sa}^* &= \left(\frac{v_{ta1}^+ + \beta(v_{tb1}^+ - v_{tc1}^+)}{\sum_{j=a,b,c} v_{tj}^{+2}} \right) P_l \\ i_{sb}^* &= \left(\frac{v_{tb1}^+ + \beta(v_{tc1}^+ - v_{ta1}^+)}{\sum_{j=a,b,c} v_{tj}^{+2}} \right) P_l \\ i_{sc}^* &= \left(\frac{v_{tc1}^+ + \beta(v_{ta1}^+ - v_{tb1}^+)}{\sum_{j=a,b,c} v_{tj}^{+2}} \right) P_l \end{aligned} \tag{9}$$

A modification in the control algorithm is required, when it is used for DVSI scheme. The following section discusses the formulation of control algorithm for DVSI scheme. The source currents, $i_{s(abc)}$ and filter currents $i_{f(abc)}$ will be equivalently represented as grid currents $i_g(abc)$ and AVSI currents $i_{\mu gx(abc)}$, respectively, in further sections.

IV. SIMULATION RESULTS

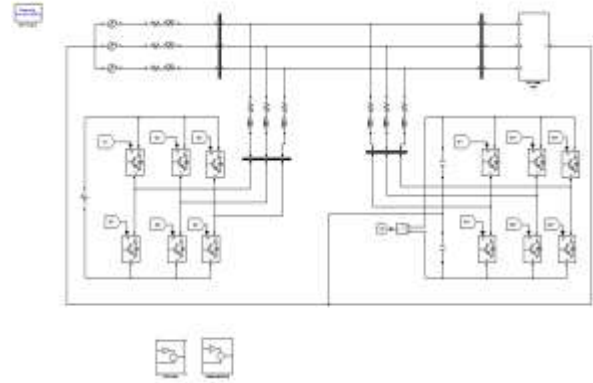

Fig 7 Matlab/simulink diagram of proposed DVSI system

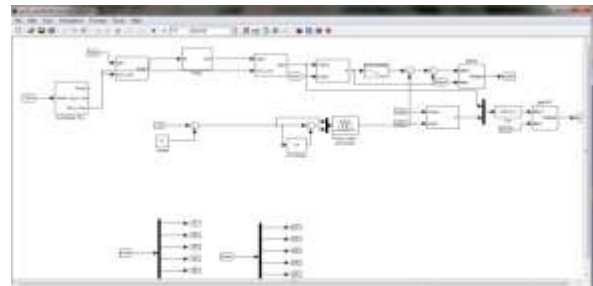

Fig 8 Controller SUBSYSTEM

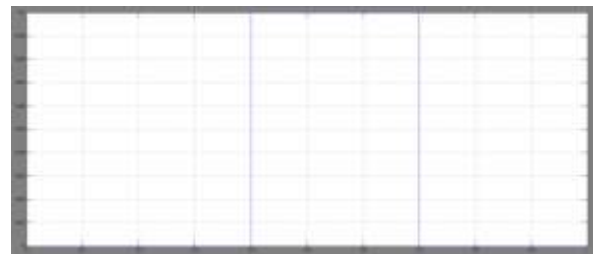

Fig 9 load active power

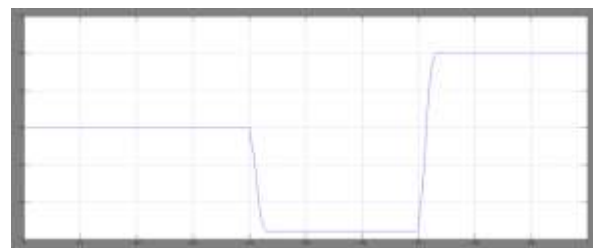

Fig 10 Active power supplied by grid

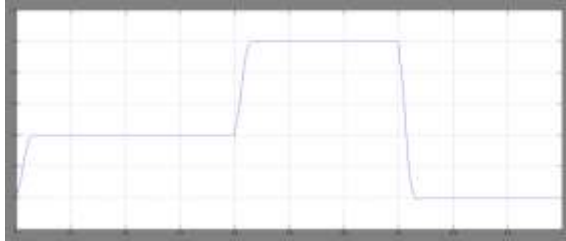

Fig 11 active power supplied by MVSI

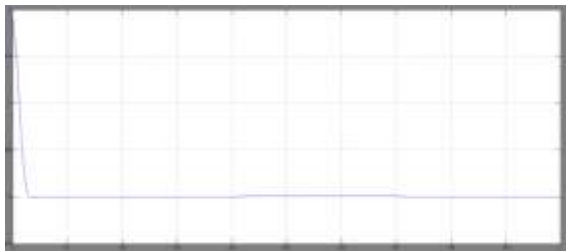

Fig 12 active power supplied by AVSI

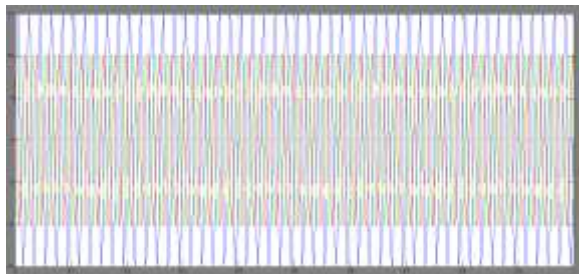

Fig 13 load currents

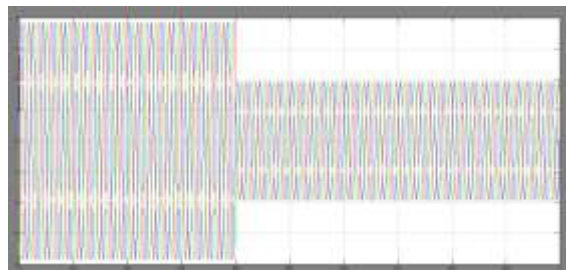

Fig 14 grid currents

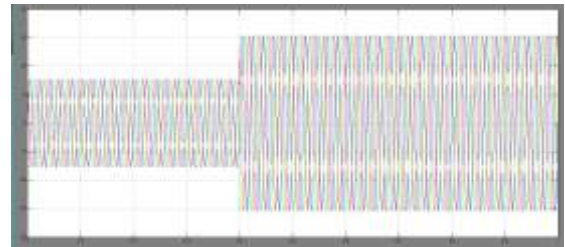

Fig 15 MVSI currents

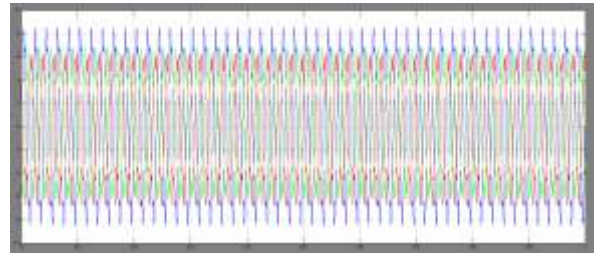

Fig 16 AVSI currents

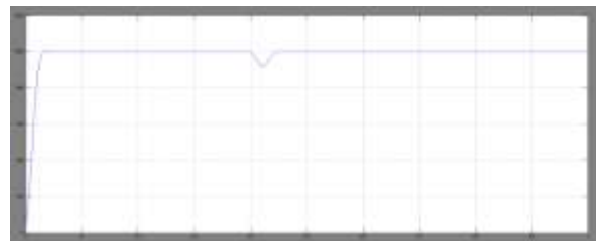

Fig 17 DC Link voltage

V.CONCLUSION

DVSI is Control algorithms are developed to generate reference currents for DVSI using ISCT. The proposed scheme has the capability to exchange power from distributed generators (DGs) and also to compensate the local unbalanced and nonlinear load. The performance of the proposed scheme has been validated through simulation studies. As compared to a single inverter with multifunctional capabilities, a DVSI has many advantages such as, increased reliability, lower cost due to the reduction in filter size, and more utilization of inverter capacity to inject real power from DGs to microgrid. Moreover, the use of three-phase, three-wire topology for the main inverter reduces the dc-link voltage requirement. Thus, a DVSI scheme is a suitable interfacing option for microgrid supplying sensitive loads. Simulation results are observed for a proposed fuzzy based DVSI.

REFERENCES

- [1] Y. Zhang, N. Gatsis, and G. Giannakis, "Robust energy management for microgrids with high-penetration renewables," *IEEE Trans. Sustain. Energy*, vol. 4, no. 4, pp. 944–953, Oct. 2013.



- [2] R. Majumder, A. Ghosh, G. Ledwich, and F. Zare, "Load sharing and power quality enhanced operation of a distributed microgrid," *IET Renewable Power Gener.*, vol. 3, no. 2, pp. 109–119, Jun. 2009.
- [3] J. Guerrero, P. C. Loh, T.-L. Lee, and M. Chandorkar, "Advanced control architectures for intelligent microgrids—Part II: Power quality, energy storage, and ac/dc microgrids," *IEEE Trans. Ind. Electron.*, vol. 60, no. 4, pp. 1263–1270, Dec. 2013.
- [4] Y. Li, D. Vilathgamuwa, and P. C. Loh, "Microgrid power quality enhancement using a three-phase four-wire grid-interfacing compensator," *IEEE Trans. Ind. Appl.*, vol. 41, no. 6, pp. 1707–1719, Nov. 2005.
- [5] M. Schonardie, R. Coelho, R. Schweitzer, and D. Martins, "Control of the active and reactive power using dq0 transformation in a three-phase grid-connected PV system," in *Proc. IEEE Int. Symp. Ind. Electron.*, May 2012, pp. 264–269.
- [6] R. S. Bajpai and R. Gupta, "Voltage and power flow control of grid connected wind generation system using DSTATCOM," in *Proc. IEEE Power Energy Soc. Gen. Meeting—Convers. Del. Elect. Energy 21st Century*, Jul. 2008, pp. 1–6.
- [7] M. Singh, V. Khadkikar, A. Chandra, and R. Varma, "Grid interconnection of renewable energy sources at the distribution level with power-quality improvement features," *IEEE Trans. Power Del.*, vol. 26, no. 1, pp. 307–315, Jan. 2011.
- [8] H.-G. Yeh, D. Gayme, and S. Low, "Adaptive VAR control for distribution circuits with photovoltaic generators," *IEEE Trans. Power Syst.*, vol. 27, no. 3, pp. 1656–1663, Aug. 2012.
- [9] C. Demoulias, "A new simple analytical method for calculating the optimum inverter size in grid-connected PV plants," *Electr. Power Syst. Res.*, vol. 80, no. 10, pp. 1197–1204, 2010.
- [10] R. Tonkoski, D. Turcotte, and T. H. M. EL-Fouly, "Impact of high PV penetration on voltage profiles in residential neighborhoods," *IEEE Trans. Sustain. Energy*, vol. 3, no. 3, pp. 518–527, Jul. 2012.
- [11] P. Rodriguez et al., "A stationary reference frame grid synchronization system for three-phase grid-connected power converters under adverse grid conditions," *IEEE Trans. Power Electron.*, vol. 27, no. 1, pp. 99–112, Jan. 2012.
- [12] S. Iyer, A. Ghosh, and A. Joshi, "Inverter topologies for DSTATCOM applications—A simulation study," *Electr. Power Syst. Res.*, vol. 75, no. 23, pp. 161–170, 2005.

AUTHOR'S PROFILE:



MANTHENA RAGHUVARAN Received the B.Tech degree in Electrical & Electronics Engineering from Holy Mary Institute of Technology & Science 2015 from JNTU, Hyderabad, Telangana, India and He is pursuing M.Tech in Electrical Power System (EPS) as specialization in the Department of Electrical & Electronics Engineering, SLC's Institute of Engineering and Technology, Affiliated to the JNTU Hyderabad, Telangana, India. His research area of interests is Power quality and Renewable energy sources.

E-mail id: raghu.mr199@gmail.com



GERA RATNA KUMARI Completed B.Tech. in Electrical & Electronics Engineering in 2006 from RVR&JC COLLEGE OF ENGINEERING, Chowdavaram, GUNTUR Dist, Affiliated to ANU, Andhra Pradesh, India and M.Tech in Power systems Engineering in 2010 from RVR&JC COLLEGE OF ENGINEERING, Chowdavaram, Guntur, Andhra Pradesh. She is currently an Assistant Professor with the Department of Electrical & Electronics Engineering at SLC'S COLLEGE OF ENGINEERING AND TECHNOLOGY JNTU, Hyderabad, Telangana, India. Her area of interest includes Power systems, design and control of power converters, power quality, renewable energy sources and FACTS.

E-mail id: ratnagera@gmail.com

**Ramavath Shankar**

Naik received the B.Tech degree in Electrical Engineering from Vignan's Engineering College, Vadlamudi, Guntur, India, in 2006. He Completed M.E in Electrical Engineering with Power system Automation as specialization in the Department of Electrical Engineering, Andhra University College of Engineering (Autonomous), Visakhapatnam, He is currently an Associate Professor with the Department of Electrical & Electronic Engineering at SLC's Institute of Engineering and Technology, JNTU University, Hyderabad, Telangana, India. His area of interest lies in Power system operation and control, optimal operation of power systems and FACTS.

E-mail id: shankar02234@gmail.com